

Indian Standard

**METHODS OF PHYSICAL TESTS FOR
HYDRAULIC CEMENT**

**PART 8 DETERMINATION OF TRANSVERSE AND COMPRESSIVE
STRENGTH OF PLASTIC MORTAR USING PRISM**

(First Revision)

First Reprint JANUARY 1993

UDC 666.942:666.971.4:539.411

© Copyright 1989

BUREAU OF INDIAN STANDARDS
MANAK BHAVAN, 9 BAHADUR SHAH ZAFAR MARG
NEW DELHI 110002

Indian Standard

METHODS OF PHYSICAL TESTS FOR HYDRAULIC CEMENT

PART 8 DETERMINATION OF TRANSVERSE AND COMPRESSIVE STRENGTH OF PLASTIC MORTAR USING PRISM

(*First Revision*)

0. FOREWORD

0.1 This Indian Standard (Part 8) (First Revision) was adopted by the Bureau of Indian Standards on 10 March 1988, after the draft finalized by the Cement and Concrete Sectional Committee had been approved by the Civil Engineering Division Council.

0.2 Standard methods of testing cement are essential adjunct to the cement specifications. This standard in different parts lays down the procedure for the tests to evaluate the physical properties of different types of hydraulic cement. The procedure for conducting chemical tests of hydraulic cement is covered in IS : 4032-1985*.

0.3 Originally all the tests to evaluate the physical properties of hydraulic cements were covered in one standard but for facilitating the use of this standard and future revisions, it has been decided to print the different tests as different parts of the standard and accordingly, this revised standard has been brought out in thirteen parts. This will also facilitate updating of

individual tests. Further, since publication of the original standard in 1968, a number of standards covering the requirements of different equipment used for testing of cement, a brief description of which was also covered in the standard, had been published. In this revision, therefore, reference is given to different instrument specifications deleting the description of the instruments, as it has been recognised that reproducible and repeatable test results can be obtained only with standard testing equipment capable of giving desired level of accuracy. This part (Part 8) covers the procedure for determination of compressive and transverse and compressive strength of plastic mortar.

0.4 For the purpose of deciding whether a particular requirement of this standard is complied with, the final value, observed or calculated, expressing the result of a test or analysis, shall be rounded off in accordance with IS : 2 - 1960*. The number of significant places retained in the rounded off value should be the same as that of the specified value in this standard.

*Method of chemical analysis of hydraulic cement (*first revision*).

*Rules for rounding off numerical values (*revised*).

1. SCOPE

1.1 This standard (Part 8) covers the procedure for determining the transverse and compressive strength of plastic mortar using prism.

2. SAMPLING AND SELECTION OF TEST SPECIMENS

2.1 The samples of the cement shall be taken in accordance with the requirements of IS : 3535-1986* and the relevant standard specification for the type of cement being tested. The representative sample of the cement selected as above shall be thoroughly mixed before testing.

3. TEMPERATURE AND HUMIDITY

3.1 The temperature of moulding room, dry materials and water shall be maintained at $27 \pm 2^\circ\text{C}$. The relative humidity of the laboratory shall be 65 ± 5 percent.

*Methods of sampling hydraulic cement (*first revision*).

3.2 The moist closet or moist room shall be maintained at $27 \pm 2^\circ\text{C}$ and at a relative humidity of not less than 90 percent.

4. APPARATUS

4.1 Balance — The balance shall conform to the following requirements:

On balance in use, the permissible variation at a load of 1 000 g shall be plus or minus 1.0 g. The permissible variation on new balance shall be one-half of this value. The sensibility reciprocal shall be not greater than twice the permissible variation.

NOTE 1 — The sensibility reciprocal is generally defined as the change in load required to change the position of rest of the indicating element or elements of a non-automatic indicating scale a definite amount at any load.

NOTE 2 — Self-indicating balance with equivalent accuracy may also be used.

4.2 Standard Weights — The permissible variations on weights in use in weighing the cement shall be as prescribed in Table 1.

TABLE 1 PERMISSIBLE VARIATIONS ON WEIGHTS

(Clause 4.2)

WEIGHTS		PERMISSIBLE VARIATION ON WEIGHTS IN USE, PLUS OR MINUS
g (1)	g (2)	
500		0.35
300		0.30
250		0.25
200		0.20
100		0.15
50		0.10
20		0.05
10		0.04
5		0.03
2		0.02
1		0.01

4.3 Planetary Mixer — Planetary mixer conforming to IS : 10890-1984*.

4.4 Moulds — Moulds conforming to 4.2 of IS : 10078-1982†.

4.5 Jolting Apparatus — Jolting apparatus conforming to IS : 10078-1982†.

4.6 Scraper — The scraper shall consist of a semi-rigid rubber blade attached to a handle about 150 mm long. The blade shall be about 75 mm long, 50 mm wide and tapered to a thin edge about 2 mm thick.

*Specification for planetary mixer used in tests of cement and pozzolana.

†Specification for jolting apparatus used for testing cement.

4.7 Demoulding Device — Demoulding device as shown in Fig. 1.

5. COMPOSITION OF MORTAR

5.1 The proportions by mass shall be one part of the cement under test, three parts of perfectly dry standard sand and 1/2 part of water (water cement ratio = 0.50). The standard sand shall conform to IS : 650-1966*. Potable/distilled water shall be used in the test.

6. PREPARATION OF MORTAR

6.1 Each mix shall be sufficient for three test specimens, that is, 450 g of cement, 1 350 g of sand and 225 g of water. Since the three sand fractions are usually of equal mass, 450 g amounts are weighed successively for the cement and for each of the coarse, medium and fine sand fractions. Mixing shall be done mechanically by means of the mixer specified in 4.3.

6.1.1 Mixing Operation — The mixture being in the operation position, the water shall be poured into the bowl and the cement added. The mixer shall be started at low speed 140 ± 5 rev/min and, after 30 s, the fine, medium and coarse sand fractions in that order shall be added steadily during the next 30 s. The mixer shall be switched to medium speed (285 ± 10 rev/min) and mixing continued for an additional 30 s.

*Specification for standard sand for testing of cement (first revision).

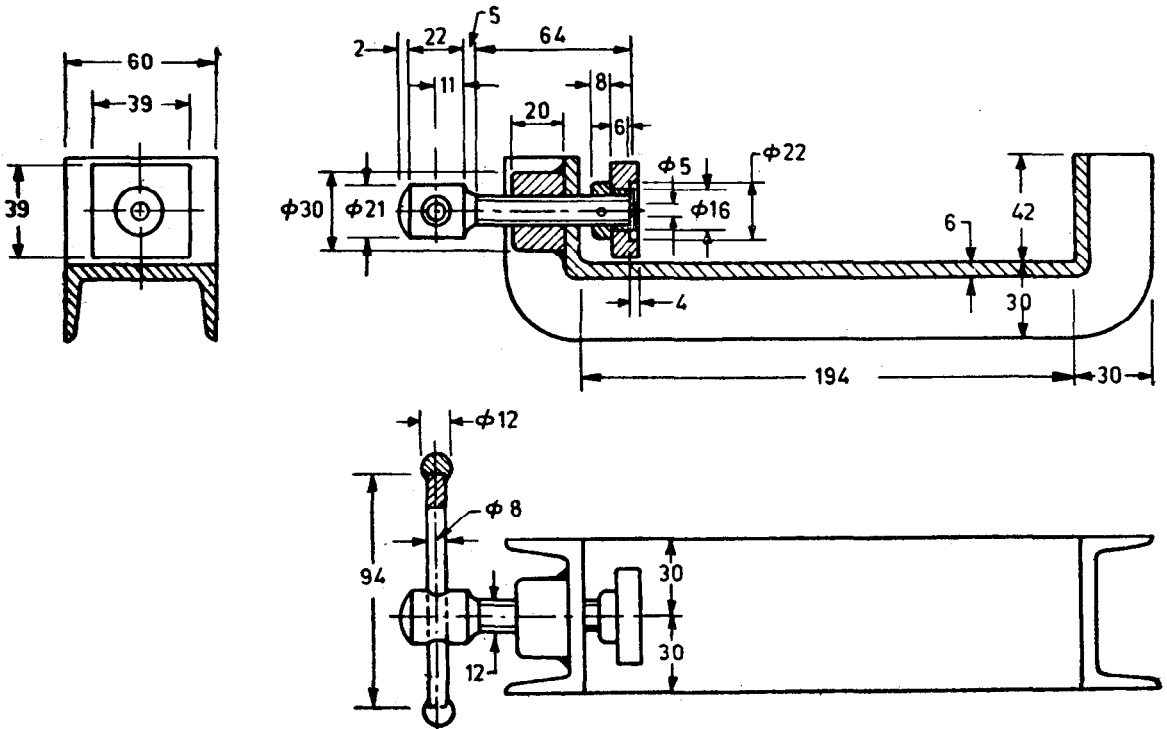

All dimensions in millimetres.
FIG. 1 APPARATUS FOR DEMOULDING SPECIMENS

The mixer shall then be stopped for 1 min 30 s. During the first 15 s, all the mortar adhering to the wall of the bowl shall be removed by means of a rubber scraper and thrown into the middle of the bowl. The bowl shall be covered during the remaining 1 min 15 s. Mixing shall then be continued at medium speed (285 ± 10 rev/min) for one minute.

7. PREPARATION AND CURING OF TEST SPECIMENS

7.1 Moulding of Test Specimens

7.1.1 The specimens shall be made in a laboratory of which the temperature shall be $27 \pm 2^\circ\text{C}$ and the relative humidity shall be 65 ± 5 percent. The moulds and all accessories shall be at this specified temperature. The moulds shall be lightly oiled inside and their external joints sealed (using, for example, a mixture of 3 parts of paraffin wax to 1 part of rosin). The mould and its hopper being fixed on the jolting table, the first layer of mortar of about 320 g shall be introduced directly from the mixer into each of the mould compartments (that is, by using a spoon of a known capacity). This layer shall be spread by means of steel plate levelling tool which is drawn twice forward and backward along the mould while processing its flanges against the top of the hopper. Sixty jolts shall be given to the first mortar layer in 60 s. A second identical layer of mortar is then introduced, levelled and compacted as previously. The mould shall then be lifted from the jolting table and its hopper removed. The excess mortar shall be struck off with a metal straight edge held nearly vertical and moved slowly along the length of the mould with a transverse sawing motion. The surface shall subsequently be lightly smoothed, using the same straight edge held almost flat.

7.1.2 Marks identifying the specimens shall be made on the moulds.

7.2 Curing of Test Specimens

7.2.1 In order to prevent evaporation of water, the moulds shall be covered by a steel or rubber sheet and placed until demoulding in a moist room or cabinet which shall be at a temperature of $27 \pm 2^\circ\text{C}$ and a relative humidity of not less than 90 percent.

7.2.2 In the case of tests at 24 h, demoulding shall be carried out 15 to 20 min before the test is due. For tests at other ages, the demoulding shall be carried out between 20 and 24 h after moulding. If the mortar has not acquired sufficient strength after 24 h to be handled without danger of deterioration, demoulding may be delayed by 24 h, but the fact shall be mentioned in the test report. Demoulding shall be done with due precautions using the demoulding device. Each demoulded test specimen shall be weighed and marked on its bottom surface. This weight is a check on the procedure.

7.2.3 After demoulding, the specimens shall be cured at $27 \pm 2^\circ\text{C}$ by immersing in water, until

the time for testing. Vertical faces as cast shall remain vertical during storage. The specimens shall be kept apart from each other, allowing free access of water to all their faces. It is convenient to replace the water every 14 days. The specimens shall be taken from the water less than 15 min before test. In order to satisfy this condition, they shall be transported to the test machine in a container full of water. They shall then be wiped with a clean cloth, so that any deposit that might have accumulated on them is removed.

8. TESTING

8.1 Bending Strength — The apparatus for bending strength tests shall consist of two supports in the form of rollers of 10 mm dia, and spaced 100 or 106.7 mm apart, on which the test prism is placed on a side face and of a third roller of the same diameter, equidistant from the first two and transmitting the load P to the opposite side face of the prism. Two of the rollers should be free to rock about their centres in order to permit uniform distribution of loads over the specimen. The prism and rollers shall be placed in electrically operated testing machine which is capable of applying and measuring small loads (less than 10 kN) with an accuracy of 1 percent in the upper 4/5 of its range. The applied load P shall be increased progressively at the rate of 50 ± 10 N/s. The breaking stress R , in N/mm^2 is $0.00234P$ or $0.00254P$, P in N, depending on whether the distance between supports is 100 or 106.7 mm. This follows from the formula:

$$R = \frac{6M}{b^3}$$

where

M = bending moment, and

b = side of the square cross-section of the prism.

8.2 Compressive Strength — After the bending strength tests, the half prisms shall be kept moist until the compressive strength tests are made. Each prism shall be tested for compressive strength on its side faces, of which an area 40×40 mm shall be placed between two hard metal plates. These shall be at least 10 mm thick, 40.0 ± 0.1 mm wide, more than 40 mm long and their surfaces shall be plane to within 0.02 mm. The plates shall preferably be of tungsten carbide or of steel, with a Vickers hardness index of at least 600 (HV 600). During the test, the plate shall be guided without friction in such a way that the upper is maintained vertically above the lower. One of the plates may be slightly inclined to permit perfect contact between it and the face of the test specimen. A typical jig used for compressive strength test is shown in Fig. 2. The plates, test specimen and suitable guides shall be placed in a compression machine, the upper platten of which shall be mounted on a freely moving ball seating centred on the axis of compression. The side or diameter of this platten shall be not larger than 100 mm on account of the small size of the test specimens. The machine

shall have an accuracy of 1 ± 1 to 1.5 percent of the smallest loads used in the tests.

8.2.1 The load shall be increased at the rate of 1 N/mm^2 per second up to about half the expected crushing load, a higher rate may be used, however, the duration of the test shall not be less than 10 s.

9. CALCULATIONS

9.1 Flexural and compressive strength shall be

expressed in N/mm^2 and shall be determined on at least 3 prisms for each age. It is advisable, as far as possible, to avoid having at each age more than two prisms from the same batch of mortar.

9.2 The test report shall give all the results but the arithmetic means from 3 bending strength tests and from 6 compressive strength tests at each age shall be taken as the bending and compressive strengths of the mortar.

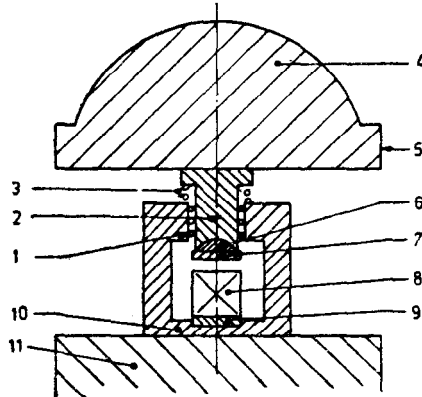

Key

- | | |
|---------------------------------|-----------------------------|
| 1. Ball bearings | 7. Upper platen of the jig |
| 2. Sliding assembly | 8. Specimen |
| 3. Return spring | 9. Lower plate |
| 4. Spherical seating of machine | 10. Lower platen of the jig |
| 5. Upper platen of machine | 11. Lower platen of machine |
| 6. Spherical seating of the jig | |

FIG. 2 TYPICAL JIG FOR COMPRESSIVE STRENGTH TEST

Bureau of Indian Standards

BIS is a statutory institution established under the *Bureau of Indian Standards Act, 1986* to promote harmonious development of the activities of standardization, marking and quality certification of goods and attending to connected matters in the country.

Copyright

BIS has the copyright of all its publications. No part of these publications may be reproduced in any form without the prior permission in writing of BIS. This does not preclude the free use, in the course of implementing the standard, of necessary details, such as symbols and sizes, type or grade designations. Enquiries relating to copyright be addressed to the Director (Publications), BIS.

Revision of Indian Standards

Indian Standards are reviewed periodically and revised, when necessary and amendments, if any, are issued from time to time. Users of Indian Standards should ascertain that they are in possession of the latest amendments or edition. Comments on this Indian Standard may be sent to BIS giving the following reference:

Amendments Issued Since Publication

Amend No.	Date of Issue	Text Affected

BUREAU OF INDIAN STANDARDS

Headquarters :

Manak Bhavan, 9 Bahadur Shah Zafar Marg, New Delhi 110002
Telephones : 331 01 31, 331 13 75

Telegrams : Manaksanstha
(Common to all Offices)

Regional Offices :

	Telephone
Central : Manak Bhavan, 9 Bahadur Shah Zafar Marg NEW DELHI 110002	{ 311 01 31 331 13 75
Eastern : 1/14 C. I. T. Scheme VII M, V. I. P. Road, Maniktola CALCUTTA 700054	37 86 62
Northern : SCO 445-446, Sector 35-C, CHANDIGARH 160036	53 38 43
Southern : C. I. T. Campus, IV Cross Road, MADRAS 600113	235 02 16
Western : Manakalaya, E9 MIDC, Marol, Andheri (East) BOMBAY 400093	6 32 92 95

Branches : AHMADABAD, BANGALORE, BHOPAL, BHUBANESHWAR, COIMBATORE,
FARIDABAD, GHAZIABAD, GUWAHATI, HYDERABAD, JAIPUR, KANPUR,
PATNA, THIRUVANANTHAPURAM.